

# ModuARC TT-250

## Pre-Engineered Welding Cell

The **ModuARC TT-250** is our lowest cost high-efficiency, pre-engineered welding cell used where no part manipulation is required during the welding process. The cell includes 2 mounting plates for easy tool mounting. All ModuARC welding cells are mounted on a common base for quick installation and mobility for future workflow adjustments.

### Standard Features:

- RTi-2000 Robot
- RCi PC Control
- K5 Teach Pendant
- RR 502 High-speed indexing table
- (2) Table Top plate modules
- Common mounting base
- Welding equipment
- Safety fencing with Arc curtains (attached to base)
- Optical Light beam barrier & gate interlocks
- Documentation
- Installation & Training

### Options:

- 3-D Touch Sense
- Through-The-Arc Seam Tracking
- Torch Cleaner with Wire Clipper
- Tooling Design & Build
- Part Programming
- Pulse, Adaptive Pulse, & Twin-Arc welding
- Fume exhaust systems

### Technical Information:

- Cell Length.....17.0'
- Cell Width.....7.9'
- Max Part Width.....34.0"
- Loading Height.....34.0"
- Weight Capacity.....550 lbs. per side

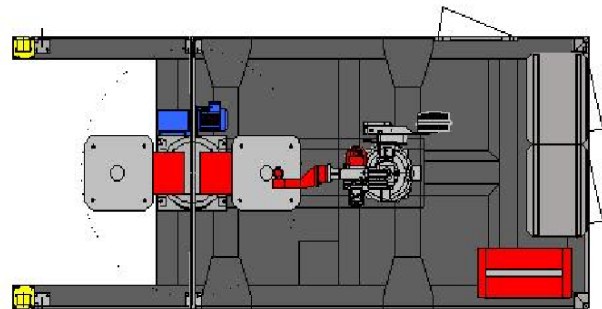

For more information, contact our sales office at: (262) 783-2720 or visit our web site at [www.igmusa.com](http://www.igmusa.com), and see what igm can do for you!